

Technical data sheet



Product features

Cooling cabinet 113 l, stainless steel

Model	SAP Code	00018382
DRR 200 S	A group of articles - web	Refrigeration and freezer cabinets



- Chamber volume [l]: 113
- Minimum device temperature [°C]: 0
- Maximum device temperature [°C]: 10
- Insulation thickness [mm]: 70
- Control type: Digital
- Interior lighting: No
- Door lock: Yes
- Opening of device: Two-sided
- Annual energy consumption [kWh]: 237

SAP Code	00018382	Gross Volume [m3]	0.407
Net Width [mm]	595	Net Volume [m3]	0.321
Net Depth [mm]	650	Minimum device temperature [°C]	0
Net Height [mm]	830	Maximum device temperature [°C]	10
Net Weight [kg]	42.00	Refrigerant	R600a
Power electric [kW]	0.158	Noise of device	51,2-52,3
Loading	230 V / 1N - 50 Hz	Load capacity [kg]	30
Energy class	B	Refrigerant weight [g]	35.00
Chamber volume [l]	113	Climate class	4

Technical data sheet



Technical drawing

Cooling cabinet 113 l, stainless steel

Model	SAP Code	00018382
DRR 200 S	A group of articles - web	Refrigeration and freezer cabinets

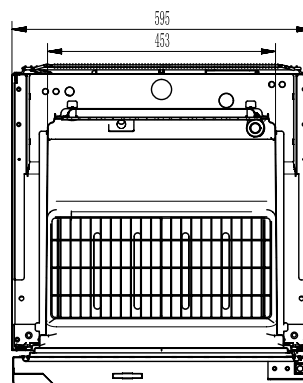
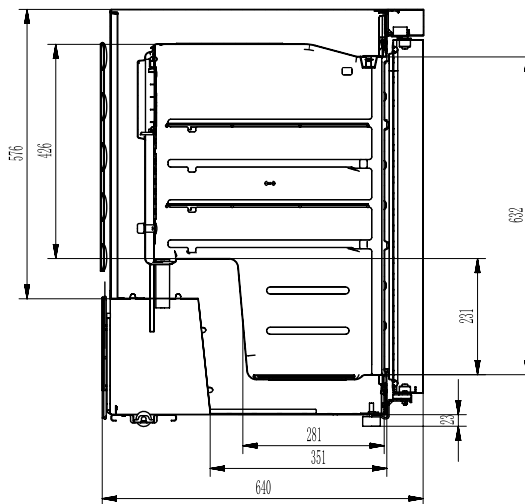
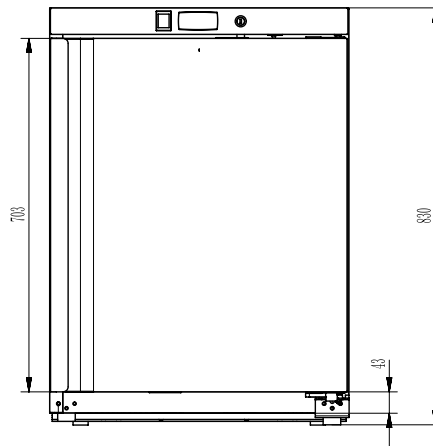

Technical data sheet



Technical parameters

Cooling cabinet 113 l, stainless steel

Model	SAP Code	00018382
DRR 200 S	A group of articles - web	Refrigeration and freezer cabinets

1. SAP Code:

00018382

2. Net Width [mm]:

595

3. Net Depth [mm]:

650

4. Net Height [mm]:

830

5. Net Weight [kg]:

42.00

6. Gross Width [mm]:

630

7. Gross depth [mm]:

680

8. Gross Height [mm]:

950

9. Gross Weight [kg]:

47.00

10. Device type:

Electric unit

11. Power electric [kW]:

0.158

12. Loading:

230 V / 1N - 50 Hz

13. Energy class:

B

14. Refrigerant:

R600a

15. Cooling type:

Static with fan

16. Material:

Stainless steel

17. Min ambient temperature [°C]:

18

18. Max ambient temperature [°C]:

43

19. Device properties 2:

Cooling

20. Chamber volume [l]:

113

21. Gross Volume [m3]:

0.407

22. Net Volume [m3]:

0.321

23. Worktop material:

SS201

24. Adjustable feet:

Yes

25. Insulation thickness [mm]:

70

26. Opening of device:

Two-sided

27. Gasket:

Yes

28. Number of doors:

1

Technical data sheet



Technical parameters

Cooling cabinet 113 l, stainless steel

Model	SAP Code	00018382
DRR 200 S	A group of articles - web	Refrigeration and freezer cabinets

29. Unit:

Yes

30. Control type:

Digital

31. Door lock:

Yes

32. Interior lighting:

No

33. Annual energy consumption [kWh]:

237

34. Minimum device temperature [°C]:

0

35. Maximum device temperature [°C]:

10

36. Defrosting cycle:

Yes

37. Noise of device:

51,2-52,3

38. Load capacity [kg]:

30

39. Refrigerant weight [g]:

35.00

40. Number of grids:

3

41. Grid size [mm x mm]:

479x405

42. Climate class:

4

43. Cross-section of conductors CU [mm²]:

0,5